

ES 3 / 7 / 8000

Interactive Management
in Price Labelling



ES 1000

ES 2000

ES 3000

ES 4000

ES 5000

ES 6000

ES 7000

ES 8000

ES 9000

More Efficiency in the Weigh Price Labelling Sector

As trendsetter for the weigh price labelling sector it is always our intention to focus on real customer's needs and requirements and to offer an easy and efficient use of our machines.

For perfect management of all production processes in weigh / price labelling, we have developed the intelligent software ESMS – the heart of our weigh price labeller. This enables all processes to be easily controlled via the touch screen – simply by entering a PID number (product identification) and a CID

number (customer identification). Using multi-tasking, the machine continues running whilst the next production run is being prepared. Focusing on customer's demands, a more time saving, easier or efficient way of labelling cannot be found.

Our machines and solutions are conceived to optimise the working processes effectively and uninterrupted along the complete operating procedure. This is why our customers really profit from our products – **A future-proof investment.**



The Highlights

Properties

- output up to 150 packs per minute
- automatic adjustment of product guides, printer, label position and label rotation
- fast change of label reels by servo device
- easy replacement of thermal print heads without customer service
- conveyor belt replacement with cable-free plug-in
- conveyors with self-adjusting quick belt tensioning device
- labelling from below with drum printer: no belt adjustment, no belt recess
- multi-tasking for uninterrupted Price Labelling

Construction

- industrial design housing in stainless steel
- stable machine base with minimum number of legs
- conveyors for long packs up to 750 mm
- thermal printer options:
 - 12 dots/mm (300 dpi), print width 104 mm
 - 8 dots/mm (200 dpi), print width 80 mm

High Performance Applicator System

- automatic height compensation up to 200 mm
- no adjustment needed for different labels
- rotation of the labels for market-dependent positioning on the pack
- no external air supply needed

Long service life and availability

- brush free drive motors
- automatic control of the printing speed
- lifting of print head between each label

ESMS terminal

- brilliant colour display with touch screen
- clear operator guidance with on-screen messages
- interactive control of the system
- convenient master data entry
- label software with true type fonts and logos
- packaging software
- pre-selection memory (no down time for article change)

Service

- remote maintenance via internet
- online software update

ES 3000

Manual Price Labelling

- ideal for low capacities and small packaging operations in the food and non-food sectors
- the right solution for packs which can not be labelled automatically
- increases efficiency in the organisation of the packaging process, e.g. for mixed cartons





ES 3012



ESD 104
large reel of labels
with 210 mm diameter



ES 3060

The ES 3000 offers a rational and flexible operation and maximum Price Labelling convenience wherever a manual solution is required – in both the food and the non-food sectors. The highly compact, robust machine made in stainless steel takes up little space and fits easily into any production environment.

The large label reel with a diameter of 210 mm minimises time lost through reel changes. The ES 3000 is particularly user-friendly with clear operating elements and a clearly arranged touch screen.

Conclusion: an all-round, refined and state of the art system for Manual Price Labelling.

ES 7000 SE

Fully Automatic Price Labelling, dynamic operation

- Price Labelling Robot to a high industrial standard
- labelling output: up to 120 packs per minute
- ideally suited for combining with packaging machines (Flowpack, Thermo Forming Machines, Top Seal, Stretch)
- additional hard- and software (for details please refer to brochure "Special Edition")



Easy serviceable opening of drum printer

Total Printer
ESD 104



ES 7011

ES 7012
with printer covers

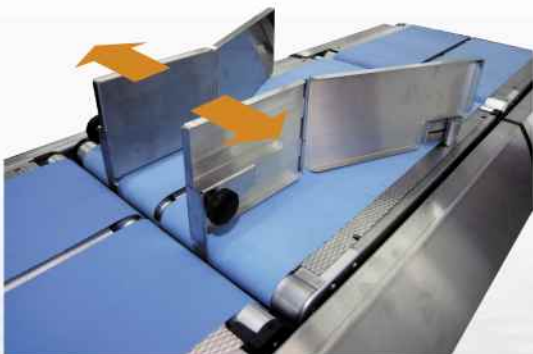

Automatic adjustment of alignment station.

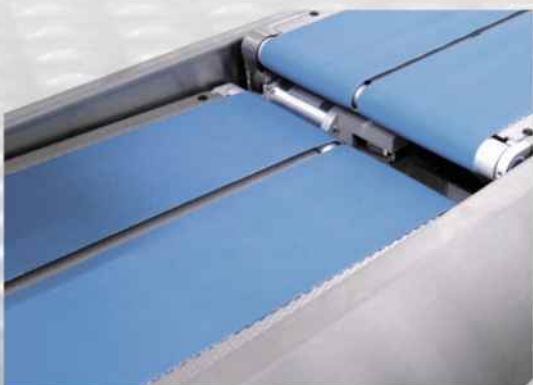

Labelling conveyor with lowering device for long packages, user-friendly with quick changeover.

The ES 7000 provides fully automatic price labelling of the highest standard. Utilizing dynamic weighing technology, the system achieves a labelling output of up to 120 packs per minute with maximum precision.

Time efficiency is enhanced by the minimisation of changing times for labels, products or packs.

The ES 7000 takes account of growing marketing demands for aesthetic label design, through a label design program and a thermal strip with high resolution.

The robust and compact stainless steel construction requires little space and cleaning is easy as it stands on only 5 legs.

ES 8000 SE

Fully Automatic Price Labelling, dynamic operation

- high-performance system for large capacities
- labelling output: up to 150 packs per minute
- interactive Price Labelling with ESMS control software
- additional hard- and software
(for details please refer to brochure "Special Edition")



The cross adjustment settings
of the printer are stored in
the pack set-up program



ES 7500

Checkweighing-Version



Protective Cover ESZ 214



ES 8100

Checkweighing-Version



ES 8001

The high-speed ES 8000 is the premier model in the range of Price Labelling Systems from ESPERA. Technical know-how, a desire for innovation and the readiness to comply rigorously with customer's requirements has resulted in a truly impressive system. With this Price Labeller a more efficient use of production time is effortlessly achieved, not only because it labels up to 150 packs per minute, but also because there are no longer any "set-up" times, i.e. while one order is in progress, preparation can be made for the next ones.

The system is managed via the ESMS control software, which makes interactive Price Labelling possible for the first time. New with this range, ESPERA offers remote maintenance via a modem. Any questions can be dealt with quickly on-line.

Additions

Splashing water protected edition

The scale has a special cabling and the weighing cell is sealed. Modules carrying mains voltage have the protection class IPX4. All add-on parts are corrosion-resistant.

The terminal ESC 964 IP65 in stainless steel protects against splash water from all sides.



encapsulated scale



IP 67 plug connection



ESC 964 IP65

ESX 104
ESX 114
Jet sorter



ESX 134
2-way reject station



ESG 214
for lateral labelling
with fully automatic
height adjustment

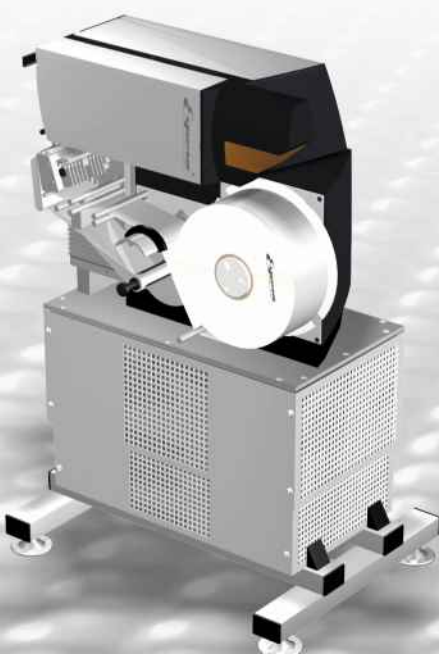



ESB 204
Barcode scanner
from above

ESB 214
Barcode scanner
from below

ESB 224
Barcode scanner
on the side



TTF
Thermal transfer



ESZ 324
Swivel device
for printer
ESD 504

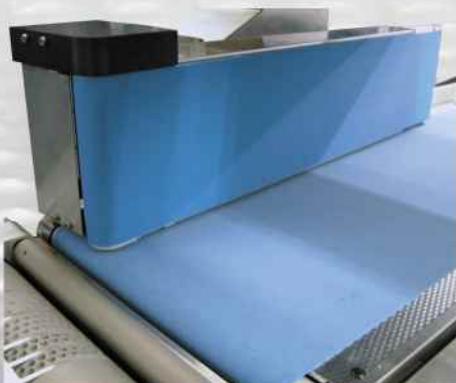

ESA 314
Driven pack alignment
for precision labelling



ESU 134
Stand for terminal ESC

Even first-class machines can be optimised in functionality by according optional additional devices. Equipment to sort accelerates effectively the final stage of weigh price labelling and saves herewith time and costs. We have also very pragmatic things in mind: Among other things we offer a protection cover that shields from splash water. Flexibility and customer orientation are our first priority.

Therefore we develop with our customers project orientated custom-made products that fit accurately in the individual company situation.

Modell	ES 3012	ES 3015	ES 3060	ES 7000	ES 8000
Pack size in mm (L x W x H)					
Max. with alignment unit		–		370 x 280 x 200	370 x 280 x 200
Max. without alignment unit		–		370 x 360 x 200	370 x 360 x 200
Max. with long pack program		–		up to L 750*	–
Labelling output packs/min.		–		up to 120	up to 150
Multiple printer operation		yes		yes	yes
Total printer		yes		yes	yes
8 Dot/mm / 200 dpi		yes		yes	yes
12 Dot/mm / 300 dpi		yes		yes	yes
Label passage		110 mm		110 mm	110 mm
Maximum printing speed		100 mm/s		300 mm/s	300 mm/s
Print head service life optimised		–		yes	yes
Print width		80 / 104 mm		80 / 104 mm	80 / 104 mm
Label minimum W x L		22 / 37 x 15 mm		37 x 37 mm	37 x 37 mm
Printer from below	–	–		52 x 37 mm	52 x 37 mm
Label maximum W x L		110 x 480 mm		110 x 200 mm	110 x 200 mm
Printer from below		–		110 x 130 mm	110 x 130 mm
Label Rotation		–		110 x 110 mm	110 x 110 mm
Label reel core		76 mm		76 mm	76 mm
Label reel outside diameter		210 mm		285 mm	285 mm
Scales		static		dynamic	dynamic
Weighing range	6 / 12 kg	3 / 6 / 15 kg	15 / 30 / 60 kg	3 / 6 / 8 kg	3 / 6 kg
Scale increment	2 / 5 g	1 / 2 / 5 g	5 / 10 / 20 g	1 / 2 / 5 g	1 / 2 g
Scale	300 x 275 mm	330 x 235 mm	540 x 430 mm	–	–
Height compensation & cross settings		–		automatic	automatic
Number of legs (basic machine)		–		5	8
Ethernet			yes		
Maintenance / Internet			yes		
USB			yes		
Memory			SSD		
Mains voltage at 50 - 60 Hz	230 V	230 V	230 V	180 - 255 V	230 V
Operating temperature			-10 °C to +40 °C		

*depends on packages and machine configurations

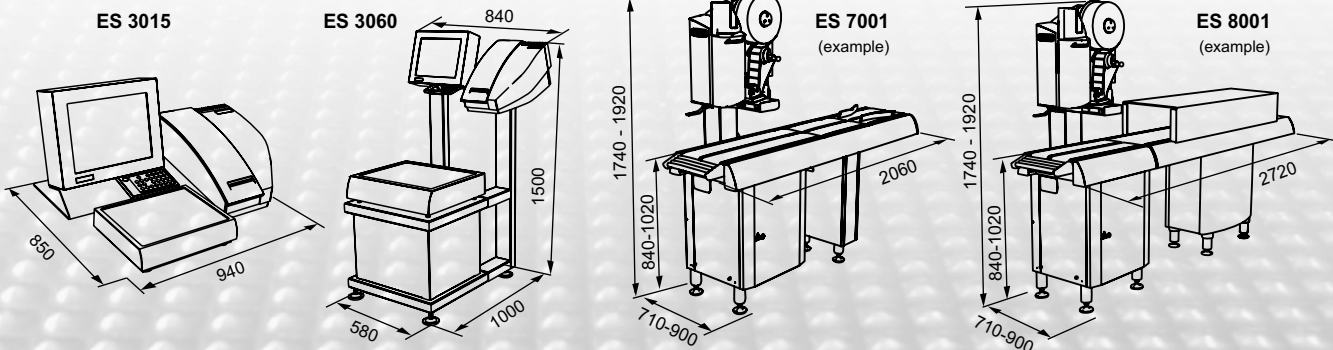

ESPERA-WERKE GMBH

P.O. Box 10 04 55 • D-47004 Duisburg
 Tel. +49(0)203/30 54 - 0 • Fax +49(0)203/30 54 - 275
 info@espera.com • www.espera.com