

Technical Data Sheet

Three-phase motor FBM 4000 Ex



More than just pumps



Advantages/characteristics:

- ▶ Brushless motor
- ▶ Increased duration possible
- ▶ Very low wear
- ▶ Maintenance-free
- ▶ Low life cycle costs
- ▶ With infinitely speed adjustment
- ▶ Very low noise level
- ▶ An extremely tough housing with double skin in aluminium
- ▶ With integrated no-volt release
- ▶ With soft-start



Technical data/type	FBM 4000 Ex
Motor type	Single phase universal motor
Housing, material	Aluminium, painted
Venting	Externally ventilated
Motor protection	Circuit breaker
Low-voltage protection	Yes
Speed setting, stepless	Yes
Power supply cable (100 - 240 V)	H 07 RN-F 3G 1,5
Power supply cable (12 - 24 V)	-
Power supply cable (42 V)	-
Standard cable length (m) ¹⁾	5
Standard plug ²⁾	CEE 7/7 ³⁾
Weight (kg)	6,1

Certificates	
Operation category as per EN 60034-1 (VDE 0530)	S1 (continuous operation)
Protection class as per DIN EN 60 529	IP 55
EC-type examination certificate number	PTB 10 ATEX 1054 X
Operating range	
Operating temperature (°C)	-20 bis +40

1) Other cable lengths available on request 2) Other plugs available on request 3) For applications outside hazardous areas

Nominal data for FBM 4000 Ex, output 600 Watt	
Nominal voltage (V)	230
Nominal frequency (Hz)	50 - 60
Nominal output (W)	600
Nominal speed (R/min)	9.200
Nominal current (A)	4,2
Protection class	I
Ex-marking	II 2G Ex d e IIC T5 Gb

Technical Data Sheet

Three-phase motor FBM 4000 Ex

Design:



FBM 4000 Ex externally ventilated with double housing.

The cooling air flows through the chambers of the double housing. The interior of the motor is thereby completely protected against corrosion of electrical components, e.g. from ambient air steam, like in electroplating units.

→ The arrows show the direction of the cooling air through the chambers of the double housing.

Dimensions [mm]:

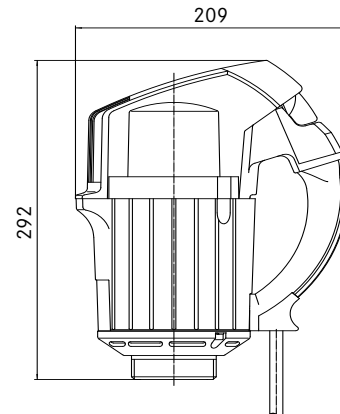

Part numbers:

Voltage (Volt)	Frequency (Hz)	Output (Watt)	Cable length (m)	Plug CEE 7/7	Part no.
Motor FEM 4070, with speed control and no-volt release					
230	50-60	600	5	Ja	10-400 01 000
			5	-	10-400 01 001