

MAGSON

Magnetically coupled centrifugal pumps



**MORE
THAN
50
YEARS**

SONDERMANN Competence
in pump and filter technologies

A  COMPANY

We all revolve around you



You want to move things? Make us find the best solution for you. The SONDERMANN brand stands for decades of experience and continuous development.

Our know-how

We know your demands. Our pumps and filters have been used all over the world for more than 50 years now. And from the beginning, we have engaged in developing custom-made products since standard designs are often not adequate for your specific requirements.

Our quality

As we are very serious about our products, each pump and filter is thoroughly checked at several stages before it leaves the company. This ensures long-lasting operation in perfect condition.

Our customer service

We are always in contact with you. Our network of representations has been much expanded: At 13 locations in Germany only, especially trained and qualified advisers are available on site to give advice and support in anything concerning the delivery of fluids.

**Count on SONDERMANN as your
reliable partner in all respects!**



SONDERMANN
PUMPEN • FILTERTECHNIK

A **FLUX** COMPANY

Contents

| | Page |
|--------------------------------|------|
| Our products | 2 |
| MAGSON – always the best | 3 |
| Design and functionality | 4 |
| Technical highlights in detail | 6 |
| Materials | 8 |
| All advantages at a glance | 9 |

MA type

Non-self priming pumps

| | |
|------------------|----|
| MA types 2 and 3 | 10 |
| MA type 4 | 12 |
| MA type 5 | 14 |
| MA type 6 | 16 |

MAS type

Self-priming pumps

| | |
|--|----|
| Functions and advantages of MAS pumps | 18 |
| MAS types 4, 5 and 6 | 20 |

Accessories

| | |
|--|----|
| Flanges, adapters, ports and fittings | 22 |
| Electronic monitoring system | 23 |
| SFU frequency converter | 24 |

Our services to you

| | |
|-------------------------------------|----|
| Customer service at its best | 25 |
| Our agencies and representatives | 26 |

Overview of new MAGSON products



| MA Non-self priming | Size | Suction port | Discharge port | | |
|------------------------|--------|--------------|----------------|-------|-------|
| Type 2 | 7/70 | G 1 1/2" | G 1 1/2" | | |
| | 8/80 | | | | |
| Type 3 | 15/40 | | | | |
| | 10/100 | | | | |
| Type 4 | 8/160 | | | DN 40 | DN 40 |
| | 10/180 | | | | |
| | 12/190 | | | | |
| Type 5 | 14/220 | | | | |
| | 10/240 | | | | |
| | 13/260 | | | | |
| | 15/280 | | | | |
| Type 6 | 18/320 | DN 50 | DN 50 | | |
| | 22/400 | | | | |
| | 26/450 | | | | |
| | 29/470 | | | | |
| | 30/510 | | | | |

| MAS Self-priming | Size | Suction port | Discharge port |
|---------------------|--------|--------------|----------------|
| Type 4 | 13/115 | | DN 25 |
| Type 5 | 17/230 | | DN 40 |
| Type 6 | 27/470 | | DN 50 |

Characteristic curves of MA pumps

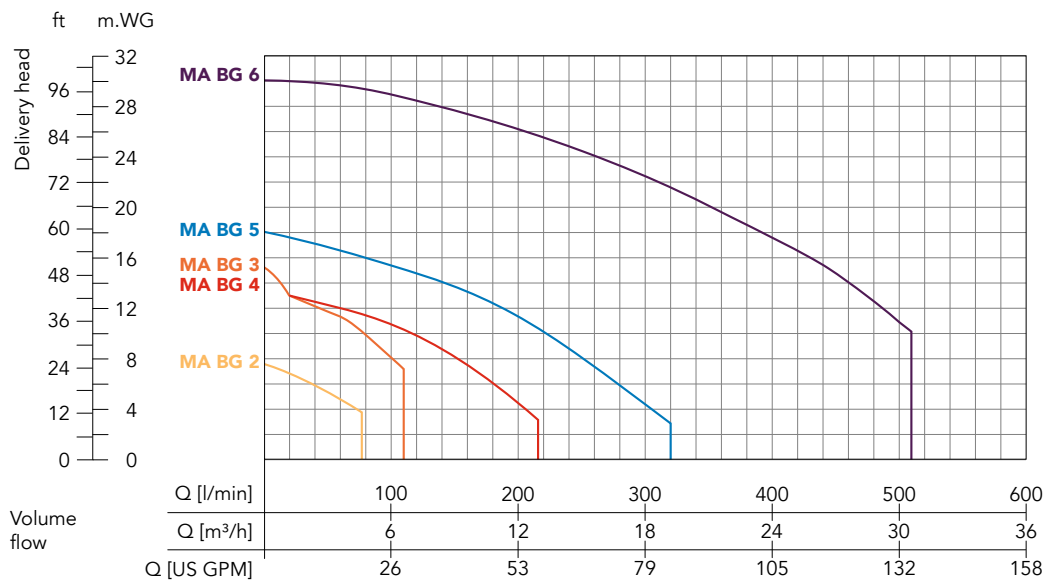

For technical data of all MA and MAS pump types see page 10 foll.

MAGSON – always the best!

The new generation of magnetically coupled centrifugal pumps without shaft seal distinguishes by top quality at extremely low life cycle costs.

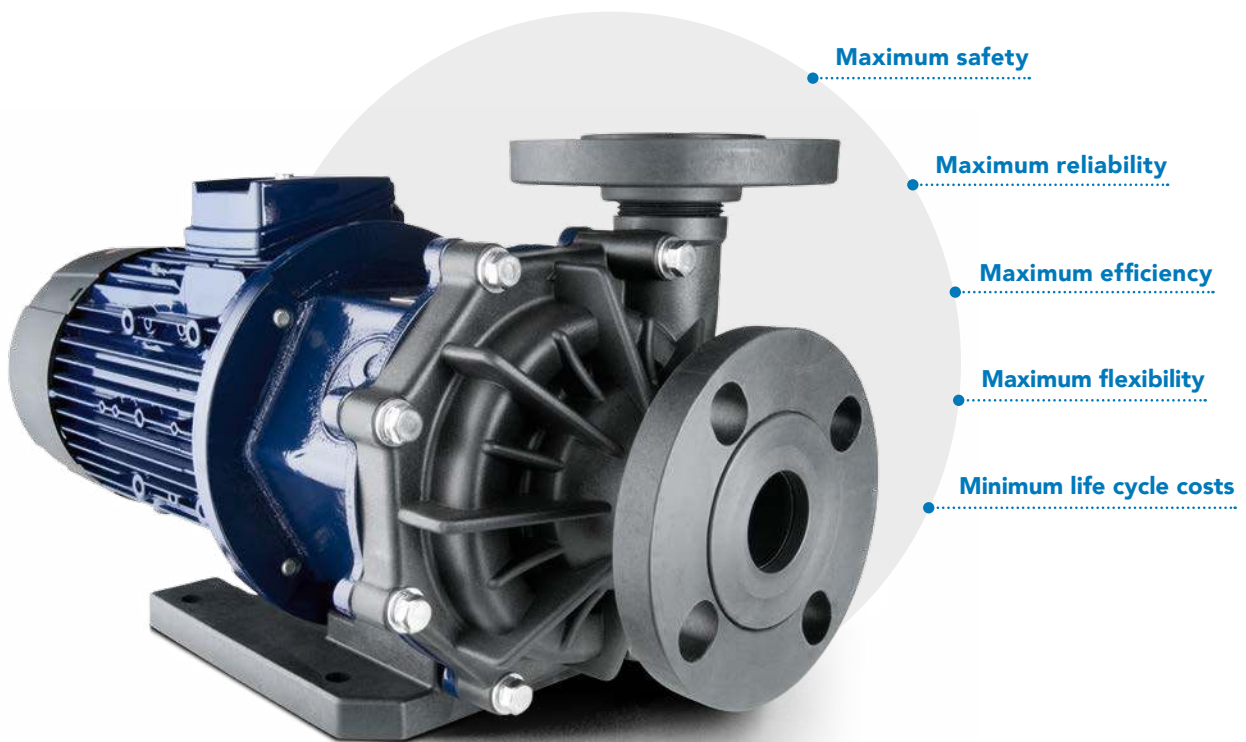

One of our fundamental principles is to always think a step ahead. So we have not just developed a new, magnetically coupled centrifugal pump without shaft seal but closely examined and analysed each part and component in order to further improve it for the benefit of our clients. This resulted in the new MAGSON pumps.

MAGSON pumps are perfect whenever absolute tightness and leakproof reliability are of utmost importance. So they are best suited to deliver highly aggressive acids and bases, degreasing baths, chemicals, highly corrosive liquids and all fluids tending to crystallize.

Top quality and innovative design assure maximum efficiency and flexibility of our products in process. In combination with SONDERMANN's comprehensive after-sales service, you can always rely on the permanent and fail-safe running of your pump system.

Benefit from our all-in package of more than 50 years of experience, specialist know-how and customer-oriented service in person. Whether you are in plant engineering, surface finishing, the chemical industry, the production of solar systems and circuit boards or electroplating, we will find the optimum pump fitting your specific mounting situation.

Always on the safe side!

No matter how acid or basic, MAGSON pumps are perfectly suited to deliver highly aggressive fluids.

As conventional centrifugal pumps are equipped with mechanical shaft seals liable to wear out, it is very difficult to run them safely incurring in particular a lot of technical efforts and high expenses when delivering highly aggressive fluids or fluids tending to crystallize. Apart from that, the maintenance work required at regular intervals considerably reduces their availability for operation.

Magnetically coupled pumps without shaft seal, however, have the advantage to be hermetically sealed and maintenance-free.

The driving magnet rotating on the outside transmits the motor power contact-free to the inner magnet and the impeller (see figure below). So there is no need of a continuous shaft nor a wearing-out seal between shaft and motor. Instead, a rear casing hermetically seals the pump

chamber from the driving motor. As a result, any leakage is impossible and the pumps do not require any maintenance.

MAGSON sets the standard of safety

MAGSON magnetically coupled centrifugal pumps even go one step further: Their sturdy design and a series of smart details further enhance their resistance to highly concentrated acids and bases, ensuring more safety when operating in critical circumstances.

In addition to non-self priming MAGSON (MA) pumps, there are also self priming pumps of the MAS type available. They are mostly used when pumps are placed above fluid level for safety reasons, eg to deliver toxic or environmentally hazardous fluids out of double-shell tanks.

 For the specific operating principle of self priming MAS pumps, see page 18.

Operating principle of MAGSON magnetically coupled centrifugal pumps:

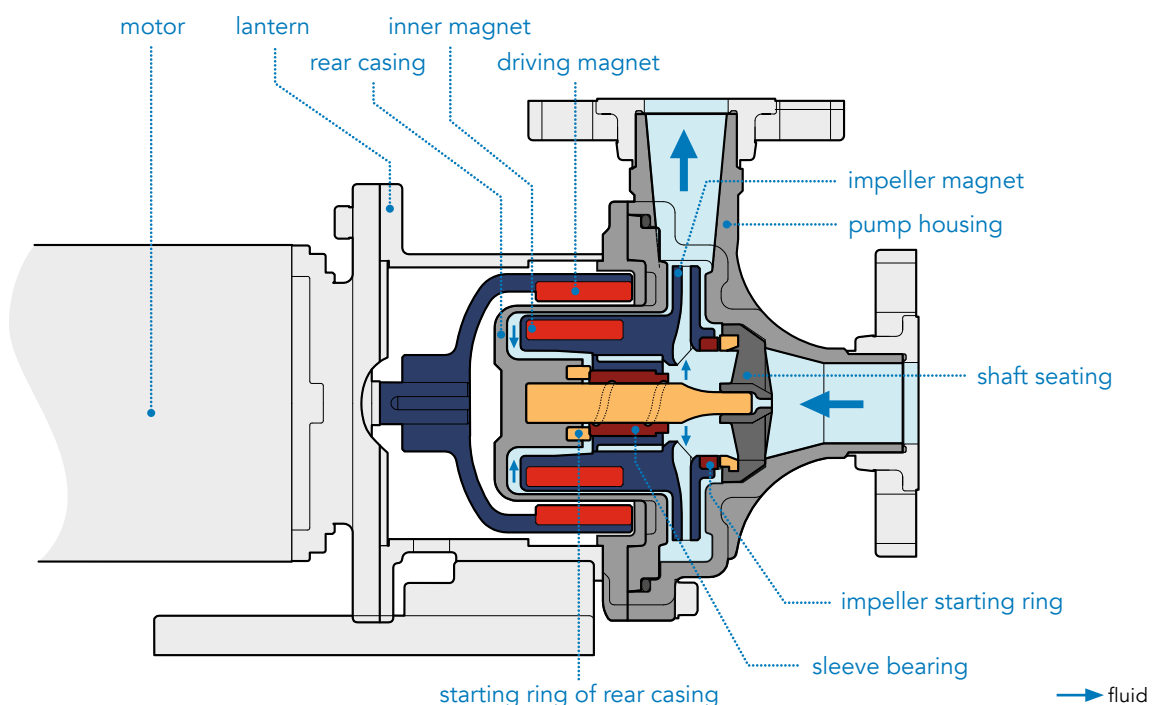

Simple and sturdy modular design:

The modular design allows you to easily replace parts, if necessary. This will considerably reduce the amount of costs and downtime.

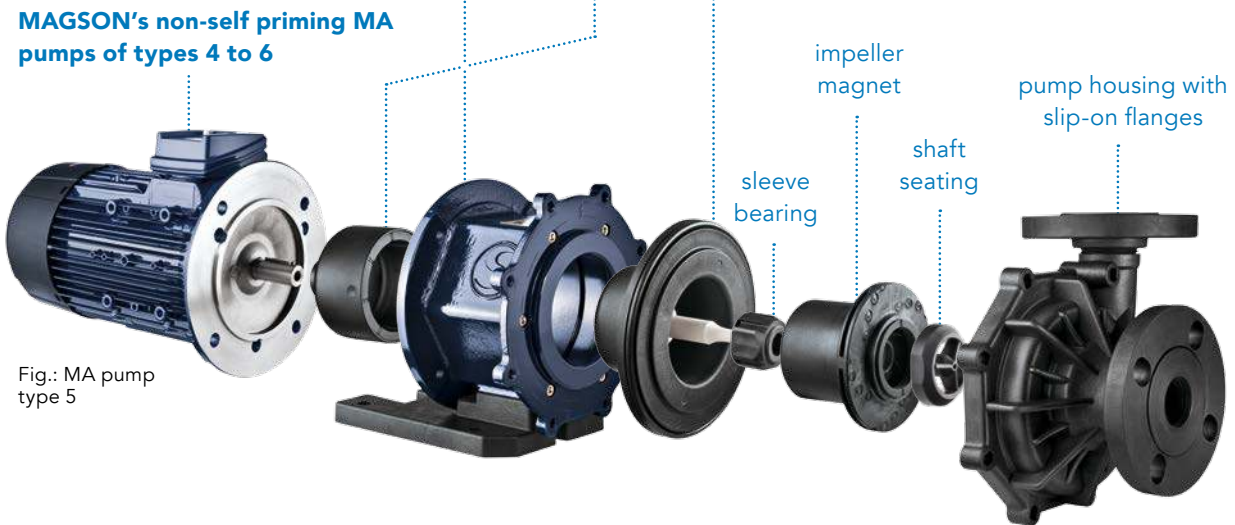
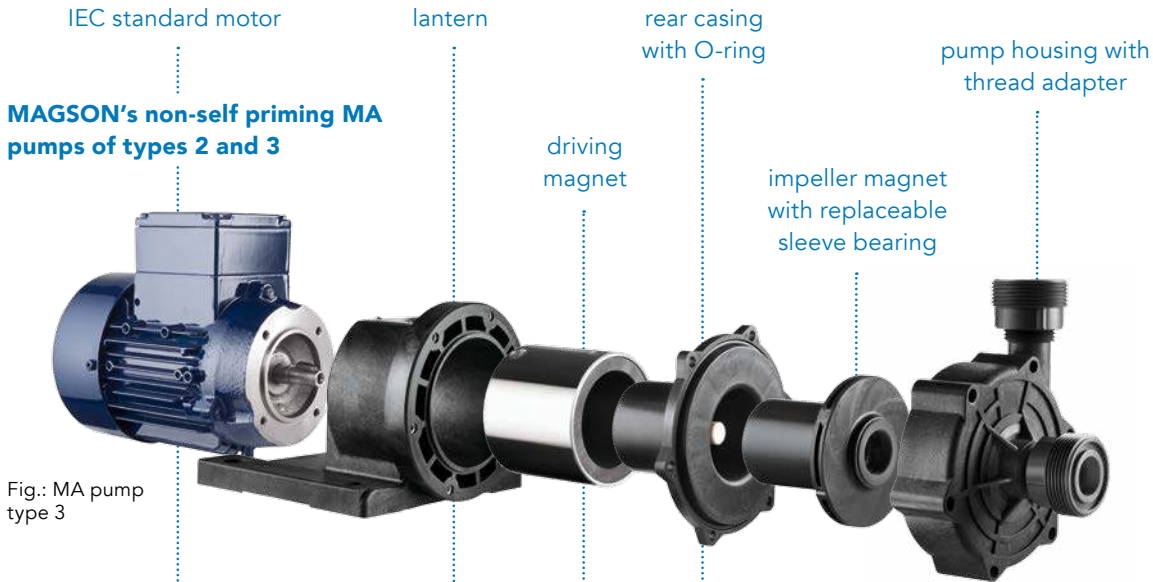

MAGSON's self-priming MAS pumps of types 4 to 6

MAGSON MA and MAS pumps are of identical design except for the housing. This means that you can convert any MA pump up from type 4 into a self-priming centrifugal pump, using a pump housing with integrated priming tank.



For further details of the MAS pump types see page 20 foll.

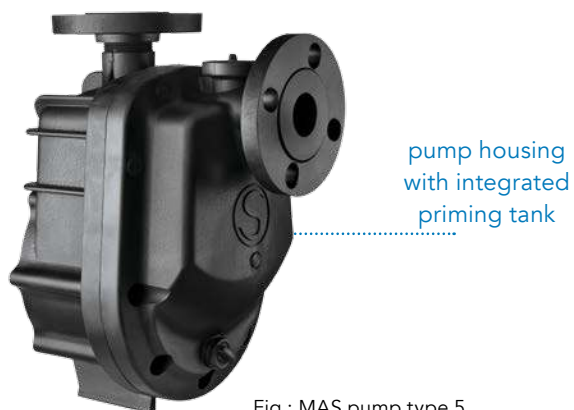

Well thought out down to the smallest detail

To deliver highly aggressive fluids even more safely and efficient, MAGSON pumps are packed with innovative features that will save you lots of money throughout their entire life cycle.

Modular design for short delivery times and rapid supply of spare parts

SONDERMANN's modular design stands for lean production. Thus, all MAGSON standard pumps are usually delivered ex works within one week. Besides, many parts and components can be exchanged straightforwardly. This also helps to simplify and speed up the supply of spare parts, and saves you from stocking up piles of spare parts – another fall in costs!

The modular design includes:

- the same shaft for all pumps of types 4 to 6
- the same sleeve bearing for all pumps of types 4 to 6
- the same rear casing for all pumps of the same type
- the same driving magnet for all pumps of the same size and with the same motor

Back pull-out to easily remove a defective motor

Due to the back pull-out design, you can replace the entire driving unit without dismantling the pumping unit so that the system stays hermetically sealed during repair or maintenance work. This reduces the downtime to a minimum.



Back pull-out (available for types 4 and higher)

Less damage in case of incomplete lubrication thanks to replaceable components

Both the centering shaft and the sleeve bearing are replaceable. Also replaceable is the shaft mounting in the housing of types 4 to 6. Their sleeve bearing has an additional plastic sheath to protect the bearing seat inside the inner magnet and the pump housing from overheating. So even in case of incomplete lubrication, most pump housings and impeller magnets remain undamaged.



Replaceable sleeve bearing with plastic sheath



Replaceable shaft seating with special fluid guidance

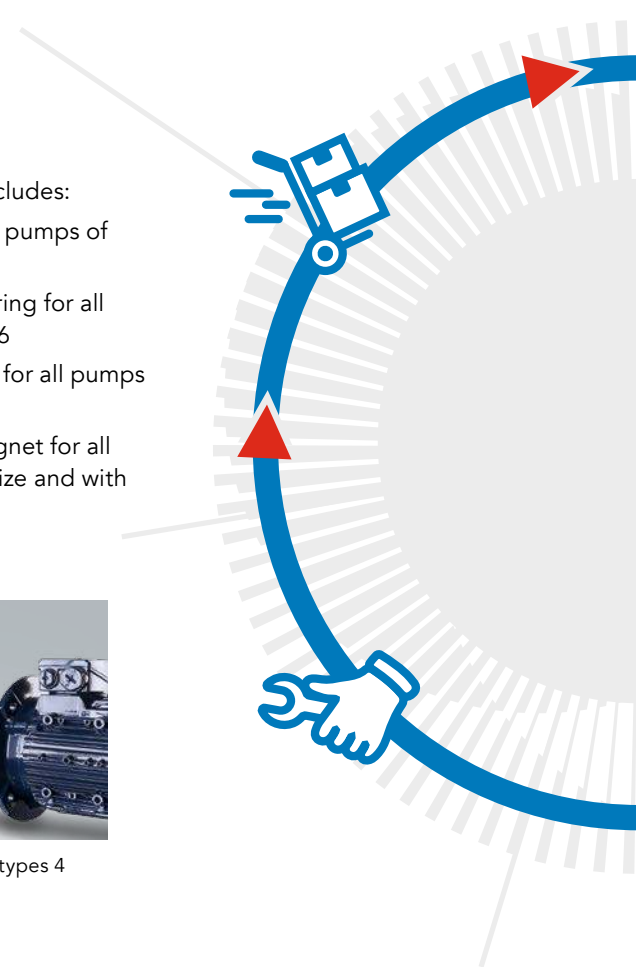



Thread adapter



Revolving slip-on flanges

Slip-on flanges and IEC standard motors for more flexibility in connecting and dimensioning

MAGSON pumps can be connected either by thread adapters or slip-on flanges (standard features of types 4 and higher). So the pumps can be adapted to any connection without incurring further installation costs.



Operation with frequency converter is also possible at any time

As standard features, the IEC three-phase AC motors can be operated with cycloconverters and PTC resistors. The frequency converter is to adjust the optimum operating point to changing conditions in order to considerably increase the efficiency of the pump.

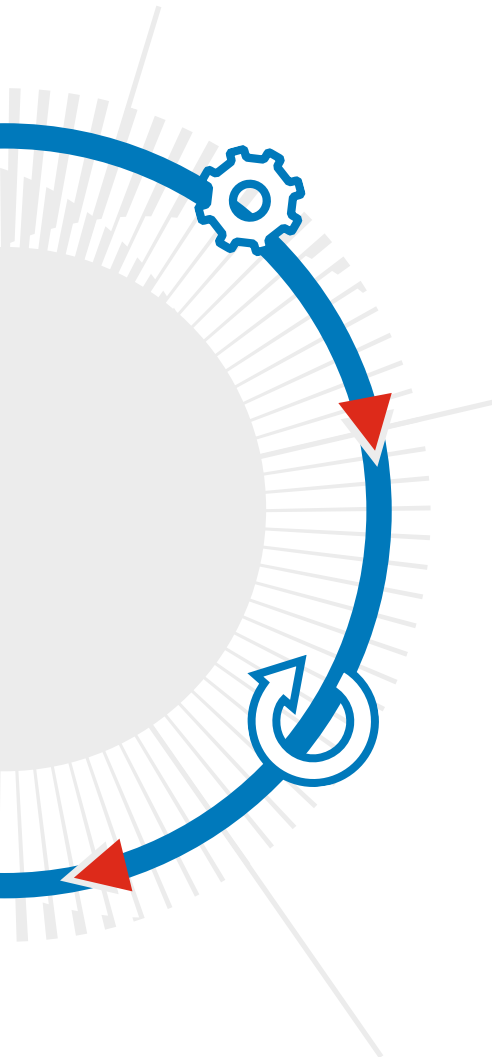

Spiral housing, centering shaft, inner magnet for safe and efficient operation

The extremely solid spiral housing (of types 4 and higher) is made in one streamlined piece to achieve utmost efficiency.

In addition, the optimum suction fluid guidance around the centering shaft (of types 4 and higher) further enhances energy efficiency and reduces operating costs.

As the inner magnet sheath is made of injection moulding without fibre reinforcement, it is highly resistant and diffusion-proof. So even the less expensive design in PP can be used with higher concentrated acids.



Streamlined spiral housing



Centering shaft with optimum fluid guidance



Inner magnet sheath made of PP without glass fibres

ETFE or PVDF?

All components that are in contact with the fluid including housing, rear casing and impeller magnet, are optionally available in PP or ETFE being especially resistant. In contrast to systems made of PVDF, you only need one ETFE pump to deliver both acids (like sulphuric acid) and bases (like caustic soda).



Our customer service

We are glad to assist you in dimensioning your pump system. See page 25.

The right material for each fluid

Whatever you want to deliver, we can offer you the appropriate combination of materials based upon concentration and temperature of the fluid.

| Component | Symbol | Material | Temperature |
|----------------------------------|----------|---|---------------|
| Components in contact with fluid | PP | Polypropylene | 0 to +70°C |
| | ETFE | Ethylene tetrafluoride ethylene | -20 to +80°C |
| | PTFE | Polytetrafluoroethylene | -20 to +100°C |
| | CFR-PTFE | Carbon fibre reinforced polytetrafluoroethylene | -20 to +100°C |
| | PPS | Polyphenylene sulphide | -20 to +100°C |
| | SIC | Silicon carbide | -20 to +100°C |
| | Alumina | Aluminium oxide ceramic (99.7%) | -20 to +100°C |
| Seals | EPDM | Ethylene-propylene-diene rubber | -20 to +100°C |
| | FKM | Fluorinated rubber | -20 to +100°C |
| | FEP | FEP-coated FKM | -20 to +100°C |

Choice of materials and type codes

The following table includes the materials of components and seals available. Please ask us to help you find the appropriate materials for the fluid to be delivered.

The type name of your MAGSON pump is made up of the material code and the features of the specific components. It consists of 8 positions (see the example below).

- Standard (off the shelf) ○ possible configuration — not available

| | Component | Material | Housing, rear casing, impeller | | | | O-ring of housing | | | | Bearing | | | Shaft and starting rings** | | | Size | Motor capacity | Motor | | Power supply frequency | |
|--------|-----------|--------------------------------|--------------------------------|---|---|---|-------------------|---|---|---|---------|---|---|----------------------------|--|--|--------------------------|----------------|-------|---|------------------------|---|
| | | | ● | ○ | — | ● | ○ | — | ● | ○ | — | ● | ○ | — | ● | ○ | | | — | ● | ○ | — |
| MA | BG2 | PP (glass-fibre reinforced*) | ● | ● | ● | ● | ○ | ○ | — | — | — | ● | ● | — | Max. delivery head / max. volume flow see technical data on pages 10 to 20 | Motor capacity (kW) see technical data on pages 10 to 20 | for 230V single-phase AC | | ● | ○ | ● | ○ |
| | BG3 | ETFE (carbon-fibre reinforced) | ● | ● | ● | ○ | ○ | — | — | — | ● | ● | — | for 230V single-phase AC | | | ● | ○ | ● | ○ | | |
| MA/MAS | BG4 | FKM | ● | ● | ● | ○ | ○ | — | — | — | ● | ○ | — | for 230V single-phase AC | | | ● | ○ | ● | ○ | | |
| | BG5 | EPDM | ● | ● | ● | ○ | ○ | — | — | — | ● | ○ | — | for 230V single-phase AC | | | ● | ○ | ● | ○ | | |
| | BG6 | FEP-coated FKM | ● | ● | ● | ○ | ○ | — | — | — | ● | ○ | — | for 230V single-phase AC | | | ● | ○ | ● | ○ | | |
| Code | | P | E | F | E | P | X | S | C | K | P | K | S | X | | | | | 1 | 3 | 5 | 6 |

For example:

MA — P — F — S — K — 8/160-0,37 — 1 — 5

* Sheath of inner magnet without fibre reinforcement

** Starting ring of impeller: CFR-PTFE (types 3 to 6)

All advantages of MAGSON pumps at a glance

Maximum safety:

- no shaft seal for hermetically sealed chemical resistance due to ETFE (better than PVDF)
- AC motors with thermal protection to avoid damage in case of motor overload
- motor can be replaced in closed system (types 4 and higher)
- self-priming MAS version available to deliver especially critical fluids out of double-shell tanks from above, for example

Maximum reliability:

- sturdy construction
- inner magnet sheath made of PP without glass fibres for higher resistance
- special suction fluid guidance counteracts cavitation (types 4 and higher)
- flow-around shaft seat to cool the sleeve bearing (types 4 and higher)

Maximum flexibility:

- ETFE can be used for both acids and bases
- slip-on flanges and thread adapters provide for flexible connection (standard features of types 4 and higher)
- use of IEC standard motors immediately available worldwide
- three-phase AC motor with standard PTC resistor for operation with cycloconverter
- modular design for short delivery times

Maximum efficiency:

- types 4 and higher with spiral housing for top efficiency and ultra-low energy consumption
- optimum suction fluid guidance for more efficiency (types 4 and higher)
- competent advice to find the perfectly dimensioned design of your MAGSON pump
- motors also available with frequency converter for the optimum operating point at all times

Minimum life cycle costs:

- low operating costs because of extremely high efficiency
- requiring no maintenance
- sleeve bearing with plastic sheath to protect the bearing seat from overheating in case of incomplete lubrication (types 4 and higher)
- low repair costs due to replaceable shaft mounting in the housing (types 4 and higher)
- short downtime and minimum expense when exchanging the motor because of the back pull-out design (types 4 and higher)
- low expenses of stocking spare parts thanks to the modular design

MA pump types 2 and 3



- without shaft seal
- streamlined housing made of PP or ETFE
- volume flow of MA pump type 2 is up to 80 l/min, of MA pump type 3 up to 100 l/min
- discharge head of MA pump type 2 is up to 8 m.Wg, of MA pump type 3 up to 15m.Wg
- horizontal single-stage monoblock design



For all advantages of MAGSON pumps see page 9.

Characteristic curves

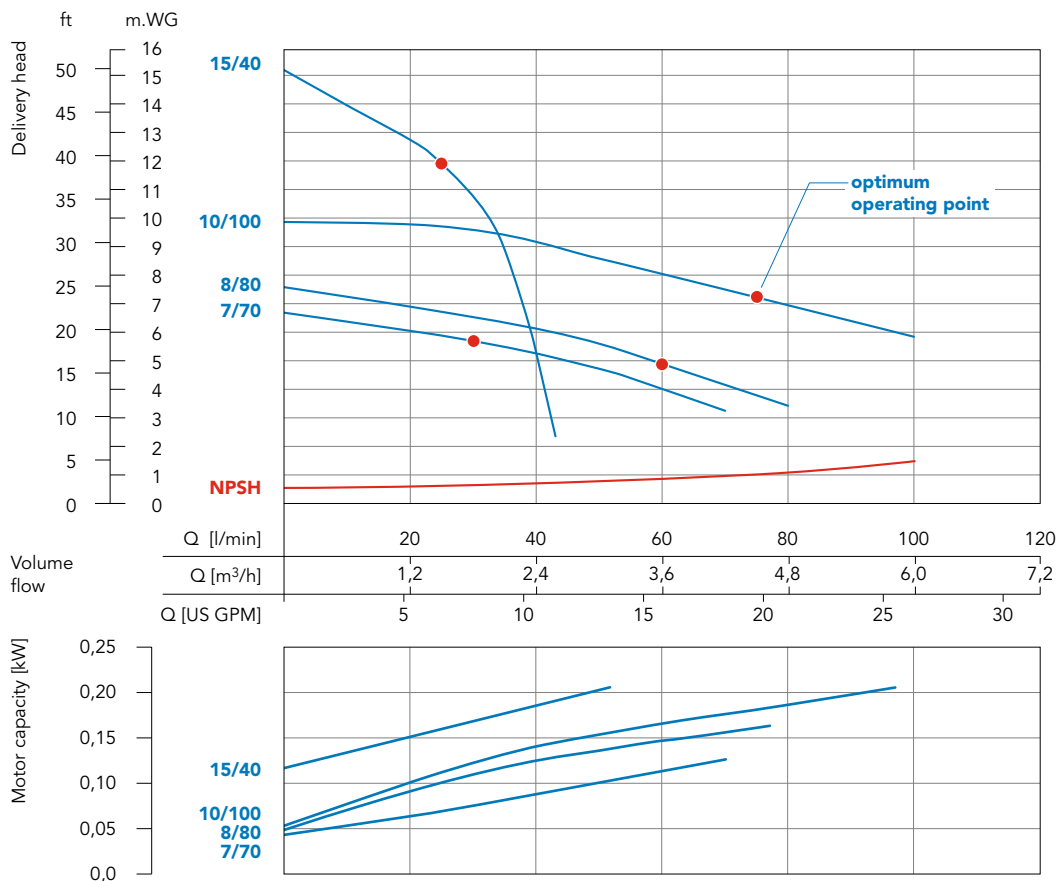

Determined with water of 20°C; measured values ± 10%

| Technical data | MA pump type 2 | | MA pump type 3 | |
|---|--|------|----------------|--------|
| | 7/70 | 8/80 | 15/40 | 10/100 |
| Material * | PP (glass-fibre reinforced) / ETFE (carbon-fibre reinforced) | | | |
| Max. delivery head in [m.WG] 50Hz | 7 | 8 | 15 | 10 |
| Max. volume flow in [l/min] 50Hz | 70 | 80 | 40 | 100 |
| Max. density in [g/cm ³] 50Hz ** | 1.9 | 1.1 | 1.1 | 1.4 |
| Motor capacity in [kW] | 0.18 | | 0.25 | |
| Current rating (400V, 50Hz) in [A] | 0.54 | | 0.71 | |
| Rated speed in [rpm] at 50Hz/60Hz | 3000/3600 | | | |
| Suction port | 1" or 1 1/2" thread with adapter | | | |
| Discharge port | 1" or 1 1/2" thread with adapter | | | |
| Voltage in [V] | 230V AC or 230/400V three-phase AC | | | |
| Protection class | IP 55 | | | |
| Max. flow velocity in [m/s] | suction side = 1 / discharge side = 3 | | | |
| Approx. weight for PP/ETFE in [kg] | 5.6 | | 6 | |
| Max. temperature for PP/ETFE in [°C] | 70/80 | | 70/80 | |
| Max. system pressure for PP/ETFE at 20°C in [bar] | 1.5 | | 2.8 | |

* Material used for housing, impeller unit and rear casing: (sheath of inner magnet made of PP without fibre reinforcement)

** approx. value at max. volume flow (higher density possible when flow rate is reduced)

Dimensions in [mm]

MA type 2

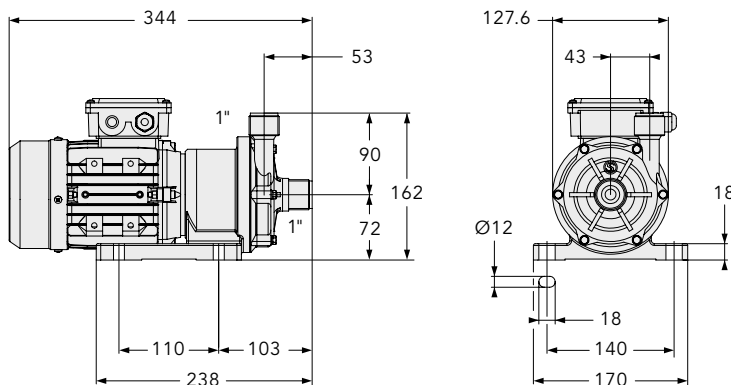

MA type 3

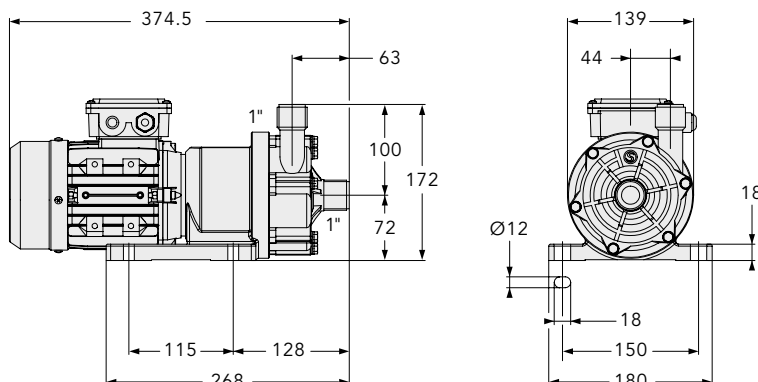

Materials

You will find all materials available and their characteristics on page 8.

Accessories

such as RPR control and frequency converters see pages 22 to 24.

Motor dimensions may differ according to manufacture.

MA type 4



- without shaft seal
- streamlined housing made of PP or ETFE
- volume flow of up to 220 l/min
- delivery head of up to 14m.WG
- back pull-out



For all advantages of MAGSON pumps see page 9.

Characteristic curves

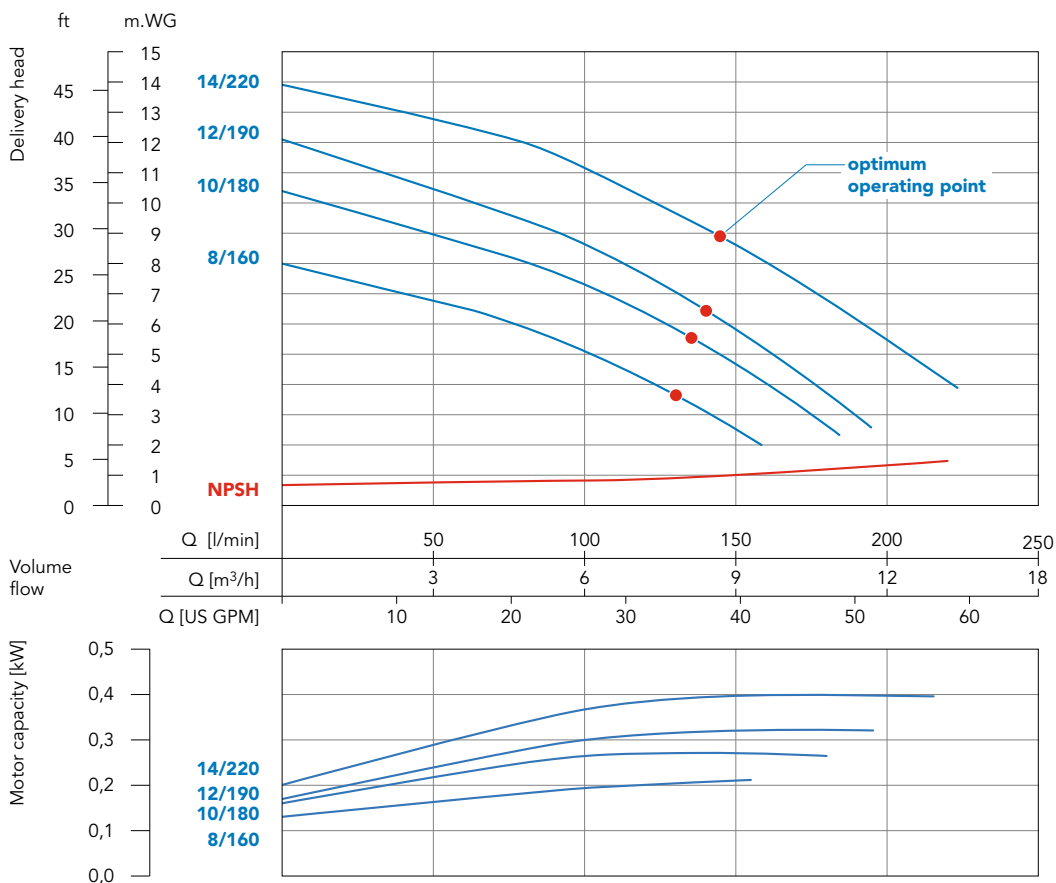

Technical data MA pump type 4

| Size | 8/160 | | 10/180 | | 12/190 | | 14/220 | |
|---|--|------|--------|------|--------|------|--------|------|
| Material* | PP (glass-fibre reinforced) / ETFE (carbon-fibre reinforced) | | | | | | | |
| Max. delivery head in [m.WG] 50Hz | 8 | | 10 | | 12 | | 14 | |
| Max. volume flow in [l/min] 50Hz | 160 | | 180 | | 190 | | 220 | |
| Max. density in [g/cm ³] 50Hz** | 1.7 | 2.6 | 1.3 | 2.0 | 1.15 | 1.7 | 0.9 | 1.4 |
| Motor capacity in [kW] | 0.37 | 0.55 | 0.37 | 0.55 | 0.37 | 0.55 | 0.37 | 0.55 |
| Current rating (400V, 50Hz) in [A] | 0.96 | 1.41 | 0.96 | 1.41 | 0.96 | 1.41 | 0.96 | 1.41 |
| Rated speed in [rpm] at 50Hz/60Hz | 3000/3600 | | | | | | | |
| Suction port | DN 40 | | | | | | | |
| Discharge port | DN 40 | | | | | | | |
| Voltage in [V] | 230V ac or 230/400V three-phase AC | | | | | | | |
| Protection class | IP 55 | | | | | | | |
| Max. flow velocity in [m/s] | suction side = 1 / discharge side = 3 | | | | | | | |
| Approx. weight for PP/ETFE in [kg] | 16 | | | | | | | |
| Max. temperature for PP/ETFE in [°C] | 70/80 | | | | | | | |
| Max. system pressure for PP/ETFE at 20°C in [bar] | 2.2 | | | | | | | |

* Material used for housing, impeller unit and rear casing: (sheath of inner magnet made of PP without fibre reinforcement)

** approx. value at max. volume flow (higher density possible when flow rate is reduced)

Dimensions in [mm]

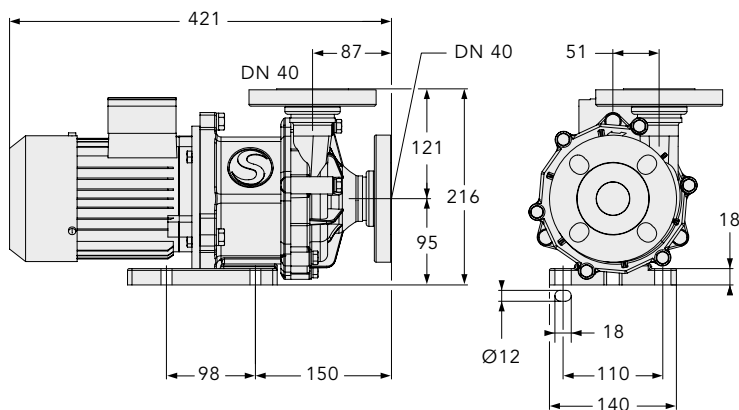

Motor dimensions may differ according to manufacture.



Materials

You will find all materials available and their characteristics on page 8.

Accessories

such as RPR control and frequency converters see pages 22 to 24.

MA type 5



- without shaft seal
- streamlined spiral housing made of PP or ETFE
- volume flow of up to 320 l/min
- delivery head of up to 18m.WG
- back pull-out



For all advantages of MAGSON pumps see page 9.

Characteristic curves

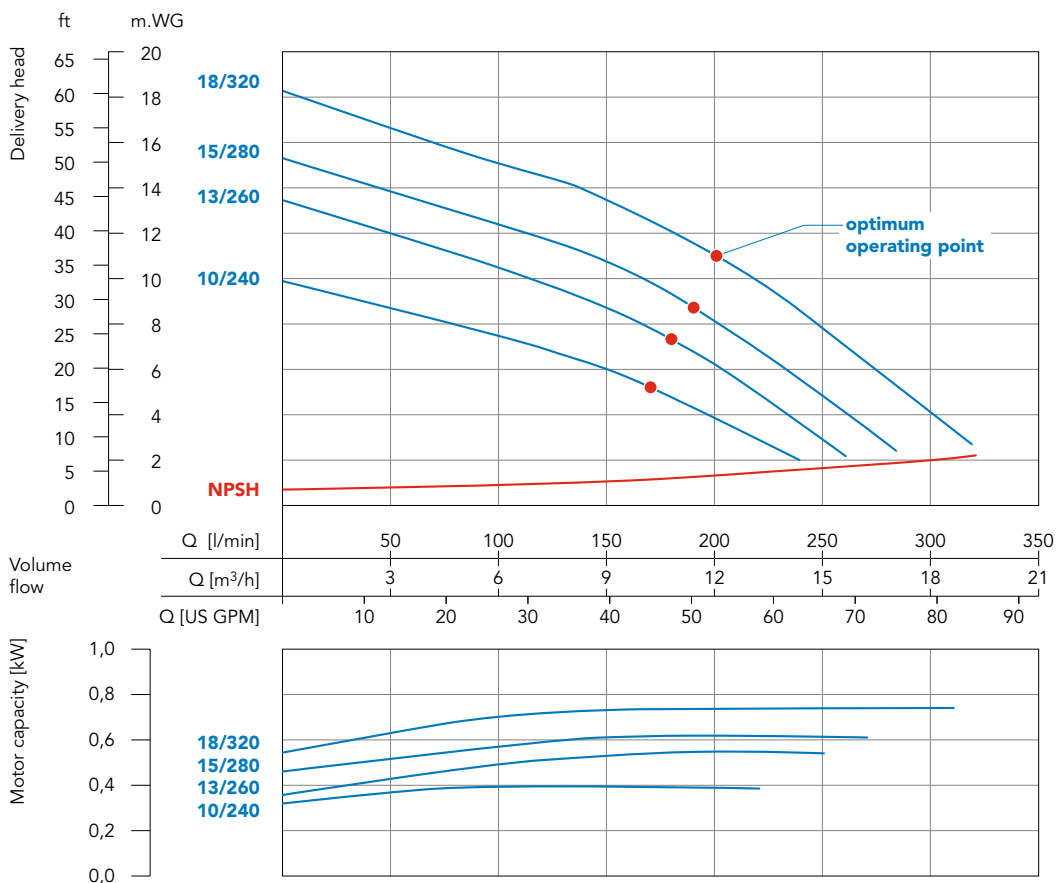

Technical data MA pump type 5

| Size | 10/240 | | 13/260 | | 15/280 | | 18/320 | |
|---|--|------|--------|------|--------|------|--------|--|
| Material* | PP (glass-fibre reinforced) / ETFE (carbon-fibre reinforced) | | | | | | | |
| Max. delivery head in [m.WG] 50Hz | 10 | 13 | | 15 | | 18 | | |
| Max. volume flow in [l/min] 50Hz | 240 | 260 | | 280 | | 320 | | |
| Max. density in [g/cm ³] 50Hz** | 1.8 | 1.3 | 2.0 | 1.2 | 1.7 | 1.0 | 1.5 | |
| Motor capacity in [kW] | 0.75 | 0.75 | 1.1 | 0.75 | 1.1 | 0.75 | 1.1 | |
| Current rating (400V, 50Hz) in [A] | 1.56 | 1.56 | 2.25 | 1.56 | 2.25 | 1.56 | 2.25 | |
| Rated speed in [rpm] at 50Hz/60Hz | 3000/3600 | | | | | | | |
| Suction port | DN 40 | | | | | | | |
| Discharge port | DN 40 | | | | | | | |
| Voltage in [V] | 230 or 400V three-phase AC | | | | | | | |
| Protection class | IP 55 | | | | | | | |
| Max. flow velocity in [m/s] | suction side = 1 / discharge side = 3 | | | | | | | |
| Approx. weight for PP/ETFE in [kg] | 22 | 22 | 25 | 22 | 25 | 22 | 25 | |
| Max. temperature for PP/ETFE in [°C] | 70/80 | | | | | | | |
| Max. system pressure for PP/ETFE at 20°C in [bar] | 3.2 | | | | | | | |

* Material used for housing, impeller unit and rear casing: (sheath of inner magnet made of PP without fibre reinforcement)

** approx. value at max. volume flow (higher density possible when flow rate is reduced)

Dimensions in [mm]

| Size | 10/240 | | 13/260 | | 15/280 | | 18/320 | |
|--------------------------|--------|-----|--------|-----|--------|-----|--------|--|
| Overall length L in [mm] | 491 | 491 | 526 | 491 | 526 | 491 | 526 | |

Motor dimensions may differ according to manufacture.

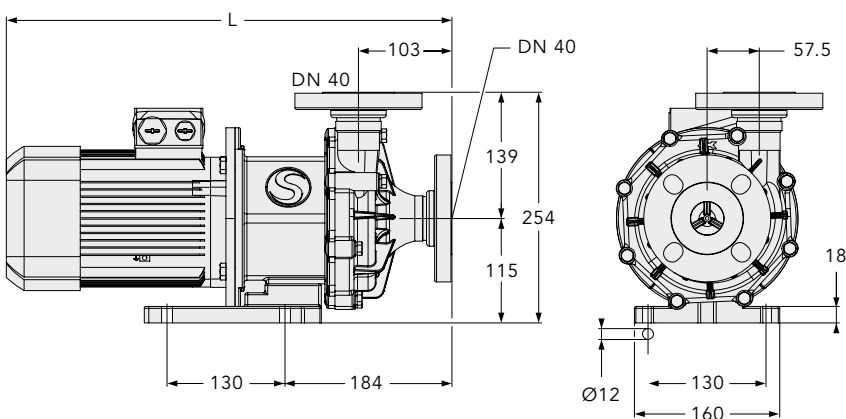

Materials

You will find all materials available and their characteristics on page 8.

Accessories

such as RPR control and frequency converters see pages 22 to 24.

MA type 6



- without shaft seal
- streamlined spiral housing made of PP or ETFE
- volume flow of up to 510 l/min
- delivery head of up to 30m.WG
- back pull-out



For all advantages of MAGSON pumps see page 9.

Characteristic curves

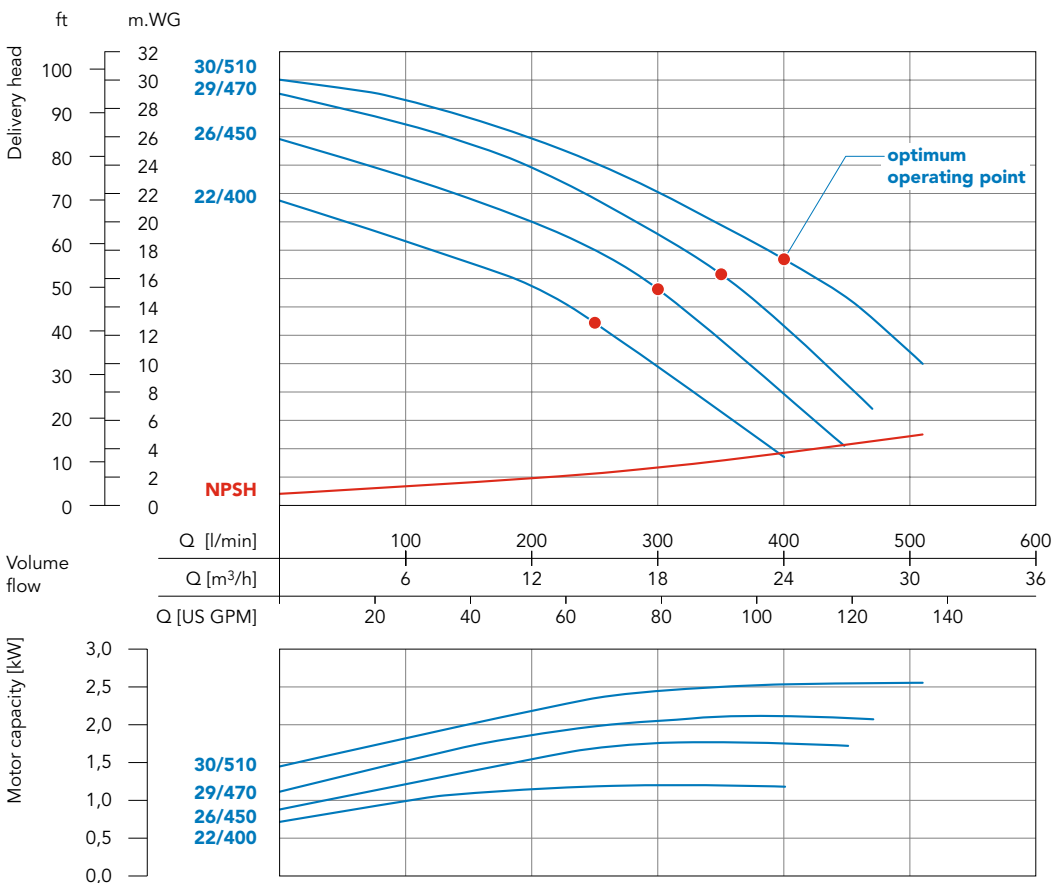

Determined with water of 20°C; measured values ± 10%

Technical data of MA pump type 6

| Size | 22/400 | | 26/450 | 29/470 | 30/510 | |
|---|--|-----|--------|--------|--------|-----|
| Material* | PP (glass-fibre reinforced) / ETFE (carbon-fibre reinforced) | | | | | |
| Max. delivery head in [m.WG] 50Hz | 22 | | 26 | 29 | 30 | |
| Max. volume flow in [l/min] 50Hz | 400 | | 450 | 470 | 510 | |
| Max. density in [g/cm ³] 50Hz** | 1.2 | 1.8 | 1.2 | 1.0 | 1.15 | 1.5 |
| Motor capacity in [kW] | 1.5 | 2.2 | 2.2 | 2.2 | 3 | 4 |
| Current rating (400V, 50Hz) in [A] | 3 | 4.2 | 4.2 | 4.2 | 5.6 | 7.3 |
| Rated speed in [rpm] at 50Hz/60Hz | 3000/3600 | | | | | |
| Suction port | DN 50 | | | | | |
| Discharge port | DN 40 | | | | DN 50 | |
| Voltage in [V] | 230 or 400V three-phase AC | | | | | |
| Protection class | IP 55 | | | | | |
| Max. flow velocity in [m/s] | suction side = 1 / discharge side = 3 | | | | | |
| Approx. weight for PP/ETFE in [kg] | 28 | 34 | 34 | 34 | 46 | 54 |
| Max. temperature for PP/ETFE in [°C] | 70/80 | | | | | |
| Max. system pressure for PP/ETFE at 20°C in [bar] | 5 | | | | 6 | |

* Material used for housing, impeller unit and rear casing: (sheath of inner magnet made of PP without fibre reinforcement)

** approx. value at max. volume flow (higher density possible when flow rate is reduced)

Dimensions in [mm]

| Size | 22/400 | | 26/450 | 29/470 | 30/510 | |
|---------------------|--------|-----|--------|--------|--------|-----|
| Dimension a in [mm] | | | 208 | | 230 | |
| Dimension c in [mm] | | | 200 | | 261 | |
| Dimension d in [mm] | | | 116 | | 135 | |
| Dimension H in [mm] | | | 261 | | 280 | |
| Dimension L in [mm] | 525 | 565 | 565 | 565 | 619 | 602 |

Motor dimensions may differ according to manufacture.

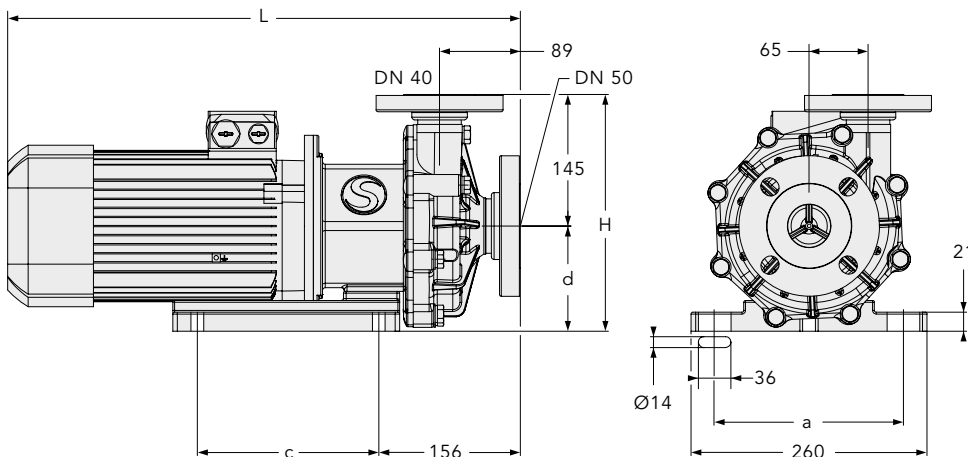

Fig.: MA pump type 6 with motor of up to 2.2kW



Materials

You will find all materials available and their characteristics on page 8.

Accessories

such as RPR control and frequency converters see pages 22 to 24.

MAGSON MAS pumps – strong, safe, self-priming

Whenever you have to deliver highly aggressive fluids out of tanks from above, self-priming pumps should be your first choice. Using a patented valveless technique, MAGSON MAS pumps feature an excellent priming capacity.



To prevent damage to the environment, most polluting and aggressive fluids are stored in double shell tanks. When delivering fluids out of such tanks, a non-self-priming centrifugal pump would have to be attached at bottom level of the tank. As the risk of leakage there is very high, this would require a lot of safety precautions.

By far the safer and less expensive thing is to use a self-priming magnetically coupled centrifugal pump. This pump also has to prime fluid, but due to its integrated priming tank takes in and delivers the fluid from the bottom up.

Being suitable to run dry for a limited period of time, MAGSON MAS pumps are also able to drain a tank down to the last drop.

Operating principle of MAGSON MAS pumps

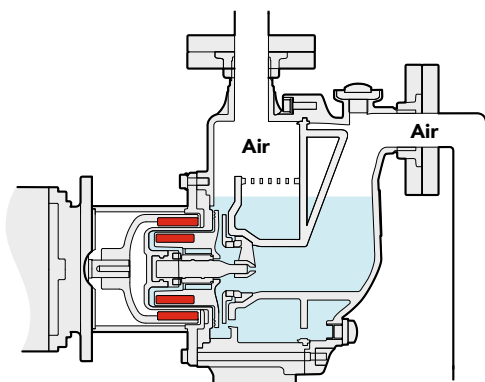

Before starting the pump

The housing with integrated priming tank has several chambers. Before starting the MAGSON MAS pump for the first time, fill it up with fluid.

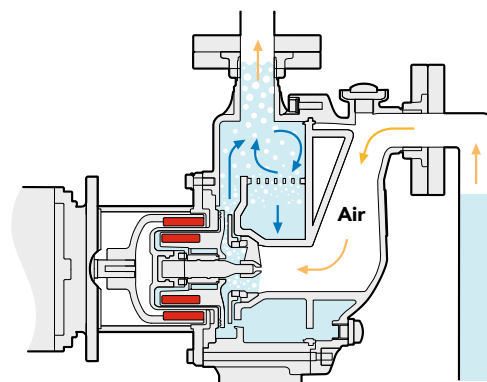

Priming

The impeller and priming chambers' design ensures that air is evacuated and a two-phase mixture (of fluid and air) is delivered without causing any damage. There is always enough fluid in the bottom chamber to supply both the impeller and the bearing with fluid.

→ Delivery flow → Air

Installation of an MAS pump in comparison to a non-self-priming MA pump

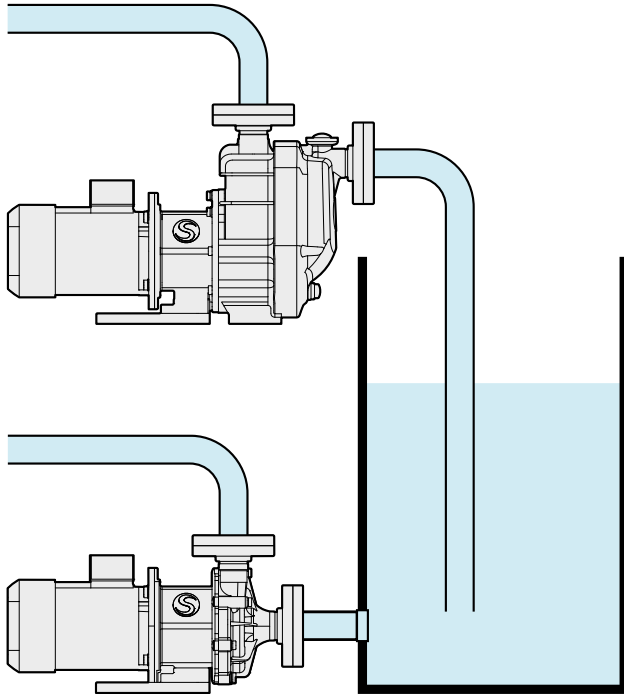

Advantages of MAS pumps are:

- excellent priming capacity of 5 m.WG in less than 2 minutes
- capacity range of up to 27 m.WG and 470 l/min
- no additional priming tank required
- being suitable to run dry for some time, they can also be used for total drainage



For all advantages of MAGSON pumps see page 9

MAGSON MAS pumps (above) prime fluid from the bottom up whereas non-self-priming MA pumps only prime horizontally.

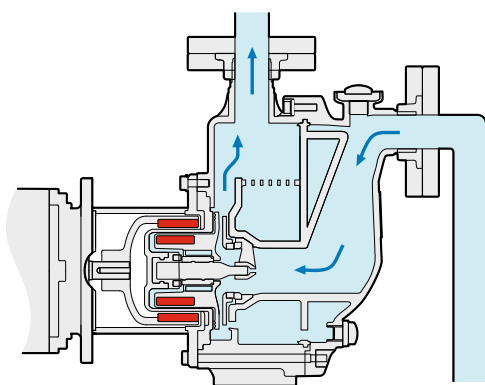

Delivery

When delivering, MAGSON MAS pumps like MA pumps operate as magnetically coupled centrifugal pumps without shaft seal in an equally reliable and efficient way.

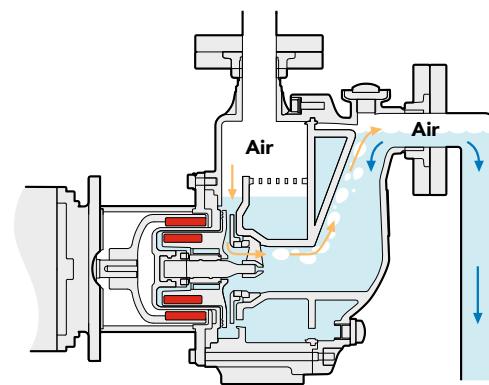

Stop

When the pump stops, the fluid in the suction line flows back into the tank. The special layout of the internal chambers makes sure that there is always enough residual fluid in the pump housing and the priming tank is not emptied totally. This patented technique does not require any valves.

MAS types 4, 5 and 6



- self-priming
- without shaft seal
- streamlined spiral housing made of PP or ETFE
- volume flow of up to 470 l/min
- delivery head of up to 27 m.WG
- back pull-out

Fig.: MAS pump type 5

 For all advantages of MAGSON pumps see page 9.

Characteristic curves

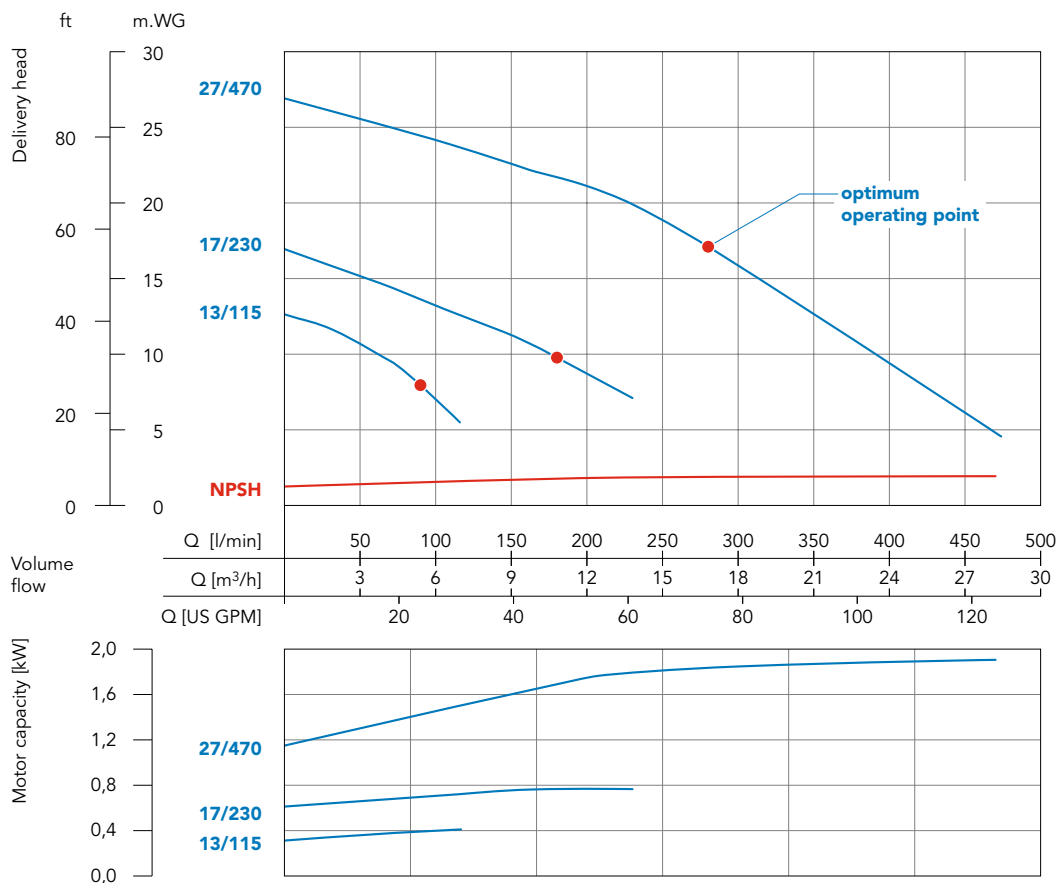

Determined with water of 20°C; measured values ± 10%

| Technical data | MAS type 4 | MAS type 5 | | MAS type 6 | | |
|---|--|------------|------|------------|---------|-----|
| Size | 13/115 | 17/230 | | 27/470 | | |
| Material* | PP (glass-fibre reinforced) / ETFE (carbon-fibre reinforced) | | | | | |
| Max. delivery head in [m.WG] 50Hz | 13 | 17 | | 27 | | |
| Max. volume flow in [l/min] 50Hz | 115 | 230 | | 470 | | |
| Max. suction head for water of 20°C in [m.WG] | 5 | | | | | |
| Max. density in [g/cm ³] 50Hz** | 1.8 | 1 | 1.4 | 1.15 | 1.6 | 2 |
| Motor capacity in [kW] | 0.75 | 0.75 | 1.1 | 2.2 | 3 | 4 |
| Current rating (400V, 50Hz) in [A] | 1.56 | 1.56 | 2.25 | 2.0 | 5.6 | 7.3 |
| Rated speed in [rpm] at 50Hz/60Hz | 3000/3600 | | | | | |
| Suction port | DN 25 | DN 40 | | DN 50 | | |
| Discharge port | DN 25 | DN 40 | | DN 50 | | |
| Voltage in [V] | 230 or 400V three-phase AC | | | | | |
| Protection class | IP 55 | | | | | |
| Max. flow velocity in [m/s] | suction side = 1 / discharge side = 3 | | | | | |
| Approx. weight for PP/ETFE in [kg] | 24 | 26 | 29 | 42 | 54 | 62 |
| Max. temperature for PP/ETFE in [°C] | 70/60 | | | | | |
| Max. system pressure for PP/ETFE at 20°C in [bar] | 2 | 2.2 | | 4 | 5.2/4.4 | |

* Material used for housing, impeller unit and rear casing: (sheath of inner magnet made of PP without fibre reinforcement)

** approx. value at max. volume flow (higher density possible when flow rate is reduced)

Dimensions in [mm]

| Size | 13/115 | 17/230 | | 27/470 | | |
|---------------------|--------|--------|-----|--------|-----|-----|
| Dimension a in [mm] | 130 | 130 | | 208 | 230 | |
| Dimension c in [mm] | 130 | 130 | | 200 | 261 | |
| Dimension d in [mm] | 255 | 276 | | 296 | | |
| Dimension e in [mm] | 70 | 84 | | 93 | | |
| Dimension f in [mm] | 167 | 190 | | 206 | | |
| Dimension g in [mm] | 275 | 305 | | 309 | | |
| Dimension i in [mm] | Ø12 | Ø12 | | Ø14×36 | | |
| Dimension J in [mm] | 196 | 228 | | 248 | | |
| Dimension H in [mm] | 325 | 360 | | 389 | | |
| Dimension K in [mm] | 18 | 18 | | 18 | 20 | |
| Dimension L in [mm] | 582 | 612 | 647 | 718 | 772 | 755 |
| Dimension w in [mm] | 160 | 160 | | 260 | | |

Motor dimensions may differ according to manufacture.

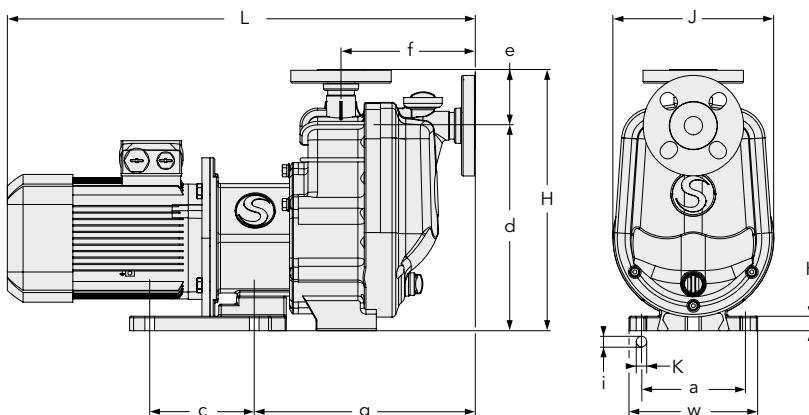

Fig.: MA pump type 6 with motor of up to 2.2kW



Materials

You will find all materials available and their characteristics on page 8.

Accessories

such as RPR control and frequency converters see pages 22 to 24.

Accessories to MAGSON pumps

Motor accessories

- ON/OFF switch with 2.5m cable and plug (230V AC only)
- 5m three-phase connection cable with CEE plug of 5 × 16 A, fully assembled
- Frequency converter of IP class 65, mounted directly to the motor or for wall mounting

Slip-on flanges

to screw onto threaded ports including O-rings*

| Type | nominal diameter of suction port | nominal diameter of discharge port | made of PP | made of ETFE |
|--------------------------|----------------------------------|------------------------------------|------------|--------------|
| MA types 2/3, MAS type 4 | DN 25 PN 10 | DN 25 PN 10 | • | • |
| MA types 4/5, MAS type 5 | DN 40 PN 10 | DN 40 PN 10 | • | • |
| MA type 6 | DN 50 PN 10 | DN 40 PN 10 | • | • |
| MAS type 6 | DN 50 PN 10 | DN 50 PN 10 | • | • |

*All MAGSON pumps of types 4, 5 and 6 come with slip-on flanges and loose thread adapters additionally enclosed as standard features.

Thread adapters

to screw onto threaded ports including O-rings connecting with insert fitting and spigot nut*

| Type | nominal diameter of suction port | nominal diameter of discharge port | made of PP | made of PVDF |
|--------------------------|----------------------------------|------------------------------------|------------|--------------|
| MA types 2/3, MAS type 4 | 1 1/2" thread | 1 1/2" thread | • | • |
| MA types 4/5, MAS type 5 | 2 1/4" thread | 2 1/4" thread | • | • |
| MA type 6 | 2 3/4" thread | 2 1/4" thread | • | • |
| MAS type 6 | 2 3/4" thread | 2 3/4" thread | • | • |

*All MAGSON pumps of types 2 and 3 come with screwed-on thread adapters as standard features.

Hose connections

Three-piece hose connections with spigot nut and hose nipple.

| Connection | hose nipple | to suction port | to discharge port |
|---------------|-------------|--------------------------|--------------------------|
| 1 1/2" thread | 1" | MA types 2/3, MAS type 4 | MA types 2/3, MAS type 4 |
| | 1 1/4" | | |
| | 1 1/2" | | |
| 2 1/4" thread | 1 1/2" | MA types 4/5, MAS type 5 | MA types 4/5/6 |
| | 2" | | |

Also available are port seals, shut-off and check valves etc. suitable to any MAGSON pump.

Our product specialists will be glad to help you!

- Standard (off the shelf)

RPR-Control 100

Electronic monitoring system to always optimize the availability of your pump

The system electronically monitors the motor current to reliably protect your MAGSON pump against dry running, overheating or overloading. In each of these cases, the RPR-Control 100 immediately switches off the pump to avoid any damage. Thus it helps to prevent downtime and all expenses resulting thereof. Once the cause of failure has been eliminated, the pump is ready for use at once.

RPR-Control 100 also allows you to monitor a set minimum flow rate. So the electronic controller detects a clogged filter and automatically demands the filter to be changed.

Advantages are:

- reliable and efficient monitoring of pumps of up to 20kW
- prevention of both damage to the pump and high outage losses
- increased availability of the pump
- trouble-free retrofitting to existing installations
- possible installation outside of pipes
- indication of due maintenance by means of the integrated hour meter



Separate programming unit

The hand-held unit with cable and plug allows you to programme switching thresholds to RPR-Control 100 1 and RPR-Control 100 3. The active-power meter integrated to RPR-Control 100 has four user-programmable switching thresholds assigned to each of the following operating conditions:

- dry running
- overheating
- overload
- flow rate falling below minimum value



RPR-Control 100 1

to be built into electrical cabinets and plug in the separate programming unit.



RPR-Control 100 2

to be built into electrical cabinets and equipped with integrated programming unit.



RPR-Control 100 3

Portable monitoring device with signal lamps and push-buttons.

SFU frequency converter

Universal drive control for utmost efficiency

MAGSON magnetically coupled centrifugal pumps are extremely efficient by nature. Using the SFU frequency converter for optimum adjustment to changing conditions, this efficiency will increase even more.

Thanks to leading-edge control technology, the SFU permanently adjusts the discharge rate to specific requirements. Whenever the rate has to be reduced or the pump has to be operated with changing volume flows, using a frequency converter will save you lots of money. Thus, the power required by a pump running at half speed is only 12% of the original demand. So the system operates with optimum efficiency but saves a lot of energy, especially in part-load operation.



Mounting on top of the motor or wall mounting optionally available.

Advantages are:

- optimum use with pumps
- decrease in operating cost by infinitely variable adjustment of the delivery rate actually required
- exceptionally high efficiency within the whole range of speed
- no additional shielded wiring required when being mounted on top of the motor
- trouble-free retrofitting to existing installations because no electrical cabinet required

Special features are:

- standard IP 65 design for installation in the field
- setting of desired values by touch-key panel, potentiometer or I/O interface
- various I/O interfaces and field bus options available

| Type | Supply | Power |
|--------------|----------|--------------|
| SFU-K-0,75/1 | 230V | 0,25–0,75 kW |
| SFU-K-1,5/3 | 3 × 400V | 0,55–1,5 kW |
| SFU-K-4,0/3 | 3 × 400V | 2,2–4,0 kW |

*All MAGSON pumps with three-phase AC motor can be used with frequency converters and have three PTC resistors each as standard features.



Calculating example

If you reduce the speed of a MAGSON MA 30/510 pump by 5 Hz, the delivery rate decreases by 12 % but at the same time, the power input falls by 28 % from 2.5 kWh to 1.8 kWh. This means an energy saving of up to 6000 kWh per year!

Customer service and support

We will help you find the right pump and optimum dimensioning of your installation.

On-site analysing

The optimum configuration of pump installations depends on various factors including the fluid to be delivered, the volume flow desired and the delivery head required. Our qualified advisers will be glad to precisely analyse your specific requirements on site and make up the optimum pump system out of the various types, designs, capacities, materials and accessories on offer, including products made by our FLUX parent company or by other suppliers.



Optimum dimensioning of your pump installation

Realizing optimum delivery rates with maximum energy efficiency is nothing like magic at all. You only have to make sure that the pump at any time runs at its optimum operating point. This requires the perfect dimensioning of the pump in accordance with overall specifications of your installation. Make use of our technical advisers' competence to optimize your operating cost and maybe even reduce the necessary investment.

We are always there for you

With more than 50 years of experience in pump and filter technologies, we are at your service for all about delivering fluids – at any time, on the phone but also in person on site.

We are always there for you, and also after sales! Just call us!

Contact us

Thanks to our wide distribution network with 13 sites in Germany, you will always find qualified advisers of SONDERMANN's or our parent company FLUX's at close range.

1 Berlin/Brandenburg

SONDERMANN Pumpen + Filter GmbH & Co. KG
August-Horch-Strasse 2
D-51149 Cologne
Phone +49 2203 9394-0
info@sondermann-pumpen.de

3 Hanover/Kassel/Magdeburg

Dipl.-Ing. (FH) Ulrich Poehls
Alte Bemeroder Strasse 122
D-30539 Hanover
Phone +49 511 517151
Mobile +49 172 6287783
u.poehls@flux-pumpen.de

5.1 Southwest North Rhine-Westphalia

Dipl.-Ing. (FH)
Joachim Kehrenbach
August-Horch-Strasse 2
D-51149 Cologne
Mobile +49 173 7162844
j.kehrenbach@sondermann-pumpen.de

2 Hamburg/Schleswig-Holstein/Mecklenburg-West Pomerania

Dipl.-Ing. (FH) Dieter Roy
Dorfstrasse 23
D-21514 Klein Pampau
Phone +49 4155 8238100
Mobile +49 172 6287782
d.roy@flux-pumpen.de

4 Bremen/Munster

Dipl.-Ing. (FH) Mathias Reimer
Am Zwickenbach 18
D-49324 Melle
Phone +49 5422 9227480
Mobile +49 170 1802546
m.reimer@flux-pumpen.de

5.2 Northeast North Rhine-Westphalia

Ralf Boesl
August-Horch-Strasse 2
D-51149 Cologne
Mobile +49 173 6055547
r.boesl@sondermann-pumpen.de



6 Hesse

Robert Hoefling
Odenwaldring 25
D-63500 Seligenstadt
Phone +49 6182 1583
Mobile +49 177 5834969
r.hoefling@flux-pumpen.de

7.1 North Baden-Württemberg

Martin Reichert
Unterer Steinweg 52/1
D-75438 Knittlingen
Phone +49 7043 952-9757
Mobile +49 174 1665762
m.reichert@flux-pumpen.de

7.2 South Baden-Württemberg

Dipl.-Ing. (FH) Dieter Roeder
Westendstrasse 4
D-75015 Bretten
Phone +49 7252 5049792
Mobile +49 172 1014217
d.roeder@flux-pumpen.de

8 South Bavaria

Tobias Anton
Kornblumenstrasse 5
D-86637 Wertingen
Mobile +49 172 6287784
t.anton@flux-pumpen.de

9 North Bavaria

Dipl.-Ing. (FH) Wolfgang Schauer
Am Weinberg 2
D-91180 Heideck
Phone +49 9177 4852705
Mobile +49 172 6287781
w.schauer@flux-pumpen.de

**10 Rhineland-Palatinate/
Saarland/Nordbaden**

Frank Schorn
Fliederstrasse 19
D-66773 Schwalbach
Phone +49 6834 567250
Mobile +49 172 6259223
f.schorn@flux-pumpen.de

16 Central Germany

Dipl.-Ing. (FH) Hendrik Mueller
Am Kirschrain 5
D-06193 Petersberg
Phone +49 34606 290321
Mobile +49 172 1324674
h.mueller@flux-pumpen.de



At your service all over the world

SONDERMANN pumps and filters are available worldwide. The contact data of our international agencies and representatives are listed at www.sondermann-pumpen.de. You may also contact us at our Cologne head office by phone no. **+49 2203 9394-0** or send an email to info@sondermann-pumpen.de.



Mehr als nur Pumpen

For more than 50 years now, SONDERMANN has been your competent partner for the wide range of FLUX pumps made by our parent company. Known for their excellent quality, FLUX pumps are available as barrel and container pumps to submersible centrifugal and eccentric screw pumps to pneumatic diaphragm pumps, mixers, liquid-flow meters, including a wide variety of accessories.



For further information on FLUX pumps and products, visit us at www.flux-pumpen.com

SONDERMANN
Pumpen + Filter GmbH & Co. KG
August-Horch-Strasse 2 · D-51149 Cologne
P.O. Box 920101 · D-51151 Cologne

Phone +49 2203 9394-0
Fax +49 2203 9394-48

info@sondermann-pumpen.de
www.sondermann-pumpen.de