



Air-operated diaphragm pumps

- Perfect for pumping abrasive and solids-bearing media
- high reliability and easy to dismantle
- wide material selection



For all the different applications pumps in massive construction or moulded design are available.

Construction features in detail

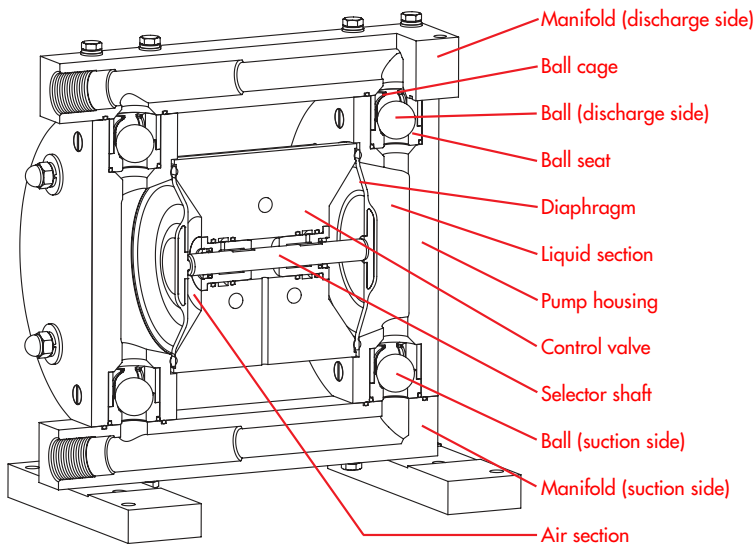

FLUX air-operated diaphragm pumps are most versatile and can be used for almost every liquid in all different fields of industry.

Be it viscous products, even with solids in suspension, abrasive fluids, high flammability or aerated liquids: FLUX air-operated diaphragm pumps meet every application featuring high operation safety and reliability.

Due to their solid construction together with matched diaphragms, these self-priming pumps are especially designed for continuous operation. FLUX air-operated diaphragm pumps ensure a very smooth liquid transfer (no shearing), are insensitive to solids in suspension, safe in dry running as well as totally overload-proof.

FLUX air-operated diaphragm pumps can be easily dismantled for an optimum cleaning. A comprehensive range of accessories guarantees a safe use of the pumps.

Function features in detail

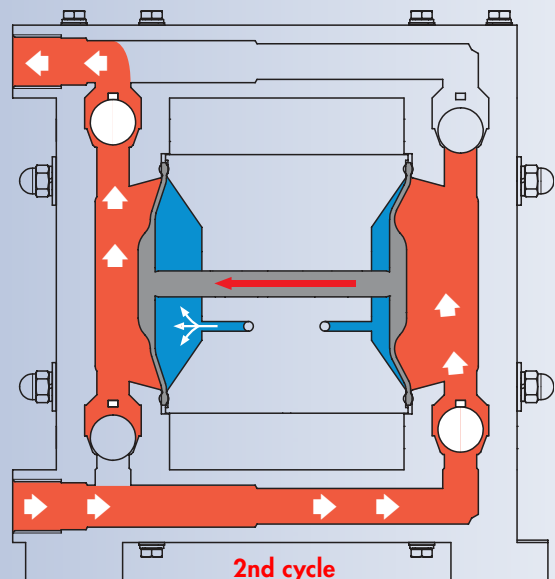
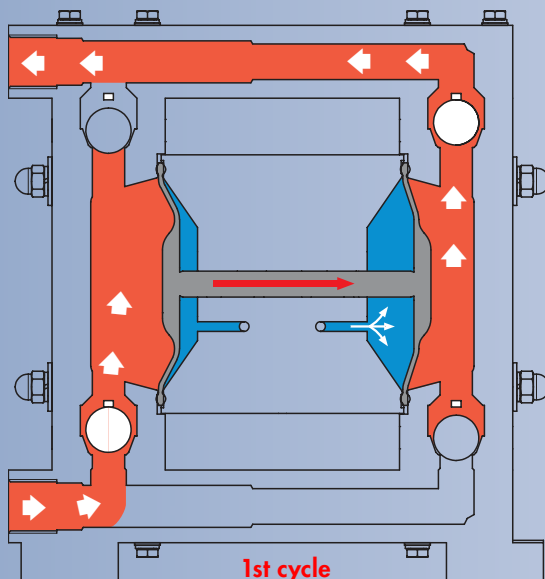

FLUX air-operated diaphragm pumps are positive displacement pumps consisting of two pump housings and one control valve part. Diaphragms within the pump housings securely separate the liquid section (red) from the air section (blue). Both diaphragms are connected by a selector shaft which is located in the control valve part.

Compressed air inflating alternately the air sections causes a movement of the diaphragms (1st and 2nd cycle). The subsequent transfer operation is controlled by a control valve which is easy to dismantle.

Due to their solid construction, the pumps are designed for continuous operation and do not require any special maintenance.

Air-operated diaphragm pumps in massive construction type RFM in different plastics

The pumps are ideal for use in different industrial sectors such as chemicals, paints, varnishes, solvents, adhesives, water and waste water and a lot more, especially when a high discharge pressure is required.

Features and benefits of the RFM air-operated diaphragm pumps:

- self priming
- four model sizes up to 375 l/min
- different plastics (polypropylene, polypropylene conductive, polytetrafluorethylene, polytetrafluorethylene conductive)
- the pump stops automatically in case of overload
- vulcanized diaphragms including a metallic core
- due to oil free operation no oil emulsive parts in the outlet air
- safe dry-running and overload-protection
- gentle displacement pumping
- variable delivery rates by simply adjusting the air pressure
- the conductive pumps are for the use in explosion proof area
- long durability of the diaphragms due to short stroke
- easy dismantling
- pump stops in case of a closed pressure side





Air-operated diaphragm pumps in moulded version type FDM in different plastics

The pumps are ideal for use in different industrial sectors such as chemicals, paints, varnishes, solvents, adhesives, water and waste water and a lot more, especially when a high discharge pressure is required.

Features and benefits of the FDM air-operated diaphragm pumps:

- self priming
- gentle displacement pumping
- different materials polypropylene (PP), polyvinylidene fluoride (PVDF), acetal (AC), aluminium ALMg5 (Al), stainless steel 1.4571 (S) and grey cast iron (GG)
- the pumps made of acetal, aluminium, stainless steel and gray cast iron are ideal for the use in explosion proof area
- safe dry-running and overload-protection
- four model sizes up to 375 l/min
- different plastics (polypropylene, polypropylene conductive, polytetrafluorethylene, polytetrafluorethylene conductive)
- the pump stops automatically in case of overload
- vulcanized diaphragms including a metallic core
- due to oil free operation no oil emulsive parts in the outlet air
- safe dry-running and overload-protection
- gentle displacement pumping
- variable delivery rates by simply adjusting the air pressure
- for use with oil emulsive air (service unit needed)
- high start-up safety at each shut-off position guarantees safe handling



FLUX-GERÄTE GMBH

Talweg 12 · D-75433 Maulbronn
Tel. 07043 101-440 · Fax 07043 101-444
info@flux-pumpen.de · www.flux-pumpen.de